

Spatial Modulation in Full-Duplex Relaying

P. Raviteja, *Student Member, IEEE*, Yi Hong, *Senior Member, IEEE*, and Emanuele Viterbo, *Fellow, IEEE*

Abstract—In this letter, we consider a multiple-input multiple-output (MIMO) source-relay-destination network, where the relay is a full-duplex MIMO transceiver (FD-MIMO) and uses spatial modulation (SM). We propose a transmission protocol for this system, where the source beamforms to the relay antennas that are not used for transmission, while the remaining antennas in the relay forward the previously decoded information using SM to the destination. We derive the analytical expressions for the bit error rate of the FD-MIMO relaying system. We show from the analytical results and simulations that our proposed FD-MIMO system outperforms the one that uses V-BLAST at relay. This performance advantage is due to the availability of more antennas at the relay dedicated to reception and the use of a lower order quadratic-amplitude modulation in SM, when compared with V-BLAST.

Index Terms—Spatial modulation, full duplex, relay, MIMO, beamforming, V-BLAST.

I. INTRODUCTION

FULL-DUPLEX (FD) is a promising new technique for wireless communications that may potentially double the spectral efficiency, when compared to half-duplex systems, by transmitting and receiving in the same time-frequency channel [1]. The FD technique has attracted a lot of research interest, and its recent developments can be found in [1] and [2].

To realise FD communication, the system has to completely cancel the high self-interference that results from its own transmission to the co-located receiver. A few approaches have been proposed to reduce self-interference by using different cancellation techniques, including passive, active analog and digital cancellation techniques. Several practical full-duplex systems were proposed that limit self-interference to a very minimum level and almost double the throughput when compared to half-duplex systems [2].

Wireless relay networks have been recognized as a promising technique to improve network coverage and reduce shadowing effect thereby increasing the network throughput [3]. Exploiting the full-duplex technique in wireless relaying network can significantly improve the network spectral efficiency, see e.g. [4].

Multiple-input multiple-output (MIMO) can be employed to further enhance throughput and reliability. Spatial modulation (SM) is a MIMO technique, which enables to reduce the number of RF chains in the transmitter. In the literature, it has been shown that SM can achieve better

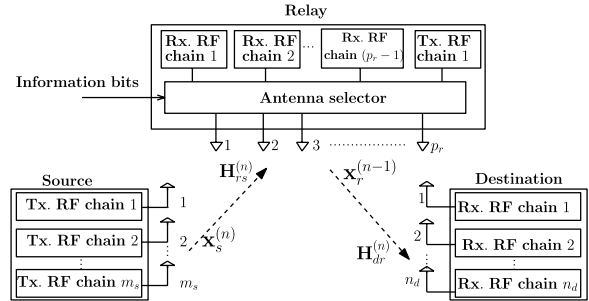

Fig. 1. The FD-MIMO relaying system.

performance than MIMO V-BLAST for a given spectral efficiency, since it uses a lower order modulation and experiences less spatial interference [5].

In this letter, we propose a transmission protocol for a MIMO source-relay-destination network, where the relay is FD and the source uses beamforming. The FD relay uses the decode-and-forward protocol and transmits using SM. We derive an approximate analytical expression of bit error rate (BER) for the proposed system and show that this approximated analytical value is very close to the simulated value. We then show with analysis and simulation that the FD system with source beamforming and SM at the relay, can outperform the same system with V-BLAST at the relay.

Finally, we note that there are some practical implementation issues of SM technique due to speed constraints of currently existing antenna switching technologies [9], which may limit the effective transmission rate and effective capacity. In our paper, we do not consider such technological limitations, which can be investigated in future work.

II. SYSTEM MODEL

Consider a MIMO source-relay-destination network, where the relay is full duplex MIMO transceiver (FD-MIMO) and uses SM, as illustrated in Fig. 1. In the rest of the paper, we call this system as the *FD-MIMO relaying* system. We use link 1 and link 2 to denote relay-source and destination-relay channels, respectively. We assume that source and destination are far apart such that destination can't receive the signal from the source.

In Fig. 1, the relay has p_r antennas, while the source and destination have m_s and n_d antennas, respectively. Moreover, the relay uses the decode-and-forward protocol and the spatial modulation (SM) technique for the transmission. In SM, only 1 antenna out of p_r will be selected at a time for transmission and the selected antenna transmits a symbol from modulation alphabet \mathbb{A}_r . The SM signal set at the relay is given by

$$\begin{aligned}
 \mathcal{SM}_{p_r, \mathbb{A}_r} &= \left\{ \mathbf{s} \in \mathbb{C}^{p_r \times 1} : s_i \in \mathbb{A}_r, \text{ when } i = j; s_i = 0 \text{ otherwise} \right\}.
 \end{aligned}$$

The index j denotes the active antenna at the relay. It can take any value from 1 to p_r depending on the information bits. The

Manuscript received June 15, 2016; revised July 6, 2016; accepted July 19, 2016. Date of publication July 22, 2016; date of current version October 7, 2016. This work was supported by the Australian Research Council through the Discovery Project under Grant DP160100528. The associate editor coordinating the review of this letter and approving it for publication was S. S. Ikki.

The authors are with the Department of Electrical and Computer Systems Engineering, Monash University, Melbourne, VIC 3800, Australia (e-mail: raviteja.patchava@monash.edu; yi.hong@monash.edu; emanuele.viterbo@monash.edu).

Digital Object Identifier 10.1109/LCOMM.2016.2593923

spectral efficiency of SM is $\lfloor \log_2 |\mathbb{A}_r| \rfloor + \lfloor \log_2 p_r \rfloor$ bits per channel use (bpcu). The relay can use $(p_r - 1)$ antennas for reception, since in the SM transmitted signals, $p_r - 1$ symbols are zero. Hence, in our system, the relay has 1 transmit RF chain and $p_r - 1$ receive RF chains. Let $m_r = p_r$ and $n_r = (p_r - 1)$ denote the number of transmit and receive antennas at the relay, respectively. We assume that the source has m_s transmit antennas and uses a modulation alphabet \mathbb{A}_s . Therefore, spectral efficiency at the source is $\lfloor \log_2 |\mathbb{A}_s| \rfloor$ bpcu, which should be equal to spectral efficiency of SM at relay $\lfloor \log_2 |\mathbb{A}_r| \rfloor + \lfloor \log_2 p_r \rfloor$ bpcu. We let $\mathbf{T}_{RS} \in \mathbb{C}^{p_r \times m_s}$ be the channel between the source and p_r antennas at the relay. We assume that \mathbf{T}_{RS} is known at the source.

We assume that transmission occurs in frames and each frame consists of N channel uses. We assume that the channel is slowly varying frequency-flat fading channel and is constant throughout the frame. Let $\mathbf{H}_{rs}^{(n)} \in \mathbb{C}^{n_r \times m_s}$ and $\mathbf{H}_{dr}^{(n)} \in \mathbb{C}^{n_d \times m_r}$ represent the channel matrices between the relay-source and destination-relay at slot n , respectively. The entries of $\mathbf{H}_{rs}^{(n)}$ and $\mathbf{H}_{dr}^{(n)}$ are i.i.d. Gaussian with zero mean and unit variance. Let $\mathbf{u}_{rs}^{(n)}$ and $\mathbf{v}_{rs}^{(n)}$ be the left and right singular vectors of the channel matrix $\mathbf{H}_{rs}^{(n)}$ corresponding to largest singular value (LSV) $\lambda_{rs}^{(n)}$, which are useful for detection at relay and beamforming at source. Let $\mathbf{w}_r \in \mathbb{C}^{n_r \times 1}$ denote the residual self interference at relay after passive suppression, analog and digital cancellations. In this letter, we assume the entries of \mathbf{w}_r are i.i.d. with each entry $\sim \mathcal{CN}(0, \sigma_{w_r}^2)$ [6].

III. THE PROPOSED PROTOCOL

We propose below a transmission protocol for the above FD-MIMO relaying system, where the FD relay uses the decode-and-forward protocol and SM for transmission.

1) In the first time slot, the source transmits the signal $\mathbf{x}_s^{(1)} \in \mathbb{C}^{m_s \times 1}$, while the relay does not have any information for transmission to destination. The relay uses the first $n_r = (p_r - 1)$ antennas for reception. Since \mathbf{T}_{RS} is available at the source, the source extracts the channel matrix $\mathbf{H}_{rs}^{(1)}$ from \mathbf{T}_{RS} by discarding the last row. Then the source beamforms the symbol $x_s^{(1)} \in \mathbb{A}_s$ to first $(p_r - 1)$ antennas at relay using right singular vector $\mathbf{v}_{rs}^{(1)}$ corresponding to the LSV of $\mathbf{H}_{rs}^{(1)}$, since this LSV based beamforming technique provides the full diversity and is efficient for low spectral efficiency applications [11, Ch. 10]. Therefore source transmits $\mathbf{x}_s^{(1)} = \mathbf{v}_{rs}^{(1)} x_s^{(1)}$ during slot 1.

In time slot 1, the received signal at relay is given by

$$\mathbf{y}_r^{(1)} = \mathbf{H}_{rs}^{(1)} \mathbf{x}_s^{(1)} + \mathbf{n}_r^{(1)},$$

where $\mathbf{y}_r^{(1)} \in \mathbb{C}^{n_r \times 1}$, $\mathbf{H}_{rs}^{(1)} \in \mathbb{C}^{n_r \times m_s}$, $\mathbf{n}_r^{(1)} \in \mathbb{C}^{n_r \times 1}$ is the noise vector at the relay with each entry $\sim \mathcal{CN}(0, \sigma_r^2)$.

The received signal at relay is multiplied by $(\mathbf{u}_{rs}^{(1)})^H$ to achieve the full diversity and the resulting received signal is $\hat{\mathbf{y}}_r^{(1)} = (\mathbf{u}_{rs}^{(1)})^H \mathbf{y}_r^{(1)}$. This signal is demodulated at relay to obtain transmitted bits from source.

2) In the second time slot, the relay converts the decoded bits from the first time slot 1 to a SM symbol and transmits $\mathbf{x}_r^{(1)} \in \mathcal{SM}_{p_r, \mathbb{A}_r}$ to the destination. Let $s_r^{(1)}$ is the QAM symbol transmitted on the active antenna. Since the source is aware of the information bits the relay is transmitting as well as

the active antenna used by relay for transmission, the source forms the channel $\hat{\mathbf{H}}_{rs}^{(2)}$ from $\mathbf{T}_{RS}^{(2)}$ by eliminating the row corresponding to the active antenna. Therefore, if the relay decodes correctly the previously transmitted symbol from the source, then $\hat{\mathbf{H}}_{rs}^{(2)} = \mathbf{H}_{rs}^{(2)}$; otherwise, there is a possibility of error propagation due to the mismatch of the channel and $\hat{\mathbf{H}}_{rs}^{(2)}$, $\mathbf{H}_{rs}^{(2)}$ have only one column difference. Hence, in time slot 2, the source transmits the signal $\mathbf{x}_s^{(2)} = \hat{\mathbf{v}}_{rs}^{(2)} x_s^{(2)}$, where $\hat{\mathbf{v}}_{rs}^{(2)}$ is the right singular vector of $\hat{\mathbf{H}}_{rs}^{(2)}$ corresponding to the LSV. The received signal at relay in time slot 2 is

$$\mathbf{y}_r^{(2)} = \mathbf{H}_{rs}^{(2)} \mathbf{x}_s^{(2)} + \mathbf{w}_r s_r^{(1)} + \mathbf{n}_r^{(2)}.$$

This signal is multiplied by $(\mathbf{u}_{rs}^{(2)})^H$ and demodulated to obtain the transmitted bits from the source. At the same time slot 2, the received signal at the destination is

$$\mathbf{y}_d^{(2)} = \mathbf{H}_{dr}^{(2)} \mathbf{x}_r^{(1)} + \mathbf{n}_d^{(2)},$$

where $\mathbf{y}_d^{(2)} \in \mathbb{C}^{n_d \times 1}$, $\mathbf{H}_{dr}^{(2)} \in \mathbb{C}^{n_d \times m_r}$, and $\mathbf{n}_d^{(2)} \in \mathbb{C}^{n_d \times 1}$ is the noise vector at the destination with i.i.d entries and each entry $\sim \mathcal{CN}(0, \sigma_d^2)$. The destination performs ML detection

$$\hat{\mathbf{x}}_d^{(2)} = \underset{\mathbf{x} \in \mathcal{SM}_{p_r, \mathbb{A}_r}}{\operatorname{argmin}} \|\mathbf{y}_d^{(2)} - \mathbf{H}_{dr}^{(2)} \mathbf{x}\|^2, \quad (1)$$

to decode the received SM symbol. Then the destination demodulates $\hat{\mathbf{x}}_d^{(2)}$ to obtain the information bits transmitted from source in time slot 1.

3) Similarly, in time slot n , the received signal at relay is

$$\mathbf{y}_r^{(n)} = \mathbf{H}_{rs}^{(n)} \mathbf{x}_s^{(n)} + \mathbf{w}_r s_r^{(n-1)} + \mathbf{n}_r^{(n)}, \quad (2)$$

where $\mathbf{x}_s^{(n)} = \hat{\mathbf{v}}_{rs}^{(n)} x_s^{(n)}$ is the transmitted signal from the source, $\mathbf{y}_r^{(n)} \in \mathbb{C}^{n_r \times 1}$, $\mathbf{H}_{rs}^{(n)} \in \mathbb{C}^{n_r \times m_s}$, and $\mathbf{n}_r^{(n)} \in \mathbb{C}^{n_r \times 1}$. The received signal at the destination is

$$\mathbf{y}_d^{(n)} = \mathbf{H}_{dr}^{(n)} \mathbf{x}_r^{(n-1)} + \mathbf{n}_d^{(n)}, \quad (3)$$

where $\mathbf{y}_d^{(n)} \in \mathbb{C}^{n_d \times 1}$, $\mathbf{H}_{dr}^{(n)} \in \mathbb{C}^{n_d \times m_r}$, and $\mathbf{n}_d^{(n)} \in \mathbb{C}^{n_d \times 1}$.

4) In the last time slot N of the frame, the source does not transmit any signal. The relay transmits $\mathbf{x}_r^{(N-1)}$ and the destination receives $\mathbf{y}_d^{(N)} = \mathbf{H}_{dr}^{(N)} \mathbf{x}_r^{(N-1)} + \mathbf{n}_d^{(N)}$ and performs ML decoding to obtain $x_s^{(N-1)}$.

IV. BER ANALYSIS

In this section, we analyze the bit error rate (BER) performance of link 1 and link 2 in FD-MIMO relaying system with the protocol proposed in Section III.

A. Link 1 BER Analysis

In the link 1 (relay-source), there are two different possible cases of detection at relay.

Case 1: In this case we assume that relay decodes previous symbol such that the decoded and original symbols have same first $\log_2 p_r$ bits, i.e., $\mathbf{H}_{rs}^{(n)} = \hat{\mathbf{H}}_{rs}^{(n)}$. In this case the resulting received signal at relay can be written as

$$\begin{aligned} \hat{\mathbf{y}}_r^{(n)} &= (\mathbf{u}_{rs}^{(n)})^H \mathbf{H}_{rs}^{(n)} \mathbf{v}_{rs}^{(n)} x_s^{(n)} + (\mathbf{u}_{rs}^{(n)})^H (\mathbf{w}_r s_r^{(n-1)} + \mathbf{n}_r^{(n)}), \\ &= \lambda_{rs}^{(n)} x_s^{(n)} + \hat{w}_r s_r^{(n-1)} + \hat{n}_r^{(n)}, \end{aligned} \quad (4)$$

where $\hat{w}_r \sim \mathcal{CN}(0, \sigma_{w_r}^2)$ and $\hat{n}_r^{(n)} \sim \mathcal{CN}(0, \sigma_r^2)$. For the system with a received signal equation $y = \lambda x + n$, where $n \sim \mathcal{CN}(0, \sigma^2)$ and λ is the largest singular value of channel \mathbf{H} whose (i, j) th entry is $\mathbf{H}_{i,j} \sim \mathcal{CN}(0, 1)$, the pair-wise error probability (PEP) $\mathcal{P}(\hat{\beta}_{x,\tilde{x}})$ is given in [7, eq. (29)] where $g P_s / \sigma^2$ equals to $\beta_{x,\tilde{x}} / 4 = |x - \tilde{x}|^2 / 4\sigma^2$. Therefore the PEP of the system in (4) can be written as

$$\mathcal{R}(\hat{\beta}_{x,\tilde{x}}) = \frac{1}{\log_2 |\mathbb{A}_r|} \sum_{s_r \in \mathbb{A}_r} \mathcal{P}(\hat{\beta}_{x,\tilde{x}}(s_r)), \quad (5)$$

where $\hat{\beta}_{x,\tilde{x}}(s_r) = |x - \tilde{x}|^2 / (\sigma_r^2 + \sigma_{w_r}^2 |s_r|^2)$. From the above, the bit error rate (BER) in this case can be written as

$$\mathcal{B}_1 \leq \frac{1}{2^\eta} \sum_{x \in \mathbb{A}_s} \sum_{\tilde{x} \in \mathbb{A}_s \setminus \{x\}} \mathcal{R}(\hat{\beta}_{x,\tilde{x}}) \frac{d_{x,\tilde{x}}}{\eta}, \quad (6)$$

where η is the spectral efficiency of the link in bpcu and $d_{x,\tilde{x}}$ is the Hamming distance of the bit labels of x and \tilde{x} . Similarly the probability that at least one of the first $\log_2 p_r$ bits are decoded wrongly is

$$\mathcal{S}_1 \leq \frac{1}{2^\eta} \sum_{x \in \mathbb{A}_s} \sum_{\tilde{x} \in \mathbb{A}_s \setminus \{x\}} \mathcal{R}(\hat{\beta}_{x,\tilde{x}}) g(x, \tilde{x}), \quad (7)$$

where $g(x, \tilde{x}) = 1$, if x and \tilde{x} have the first $\log_2 p_r$ bits differently, 0 otherwise. We refer to (7) as partial codeword error rate (PCER).

Case 2: In this case we assume that there is an error in the detection of previous symbol at relay. And this error is such that the original symbol and the decoded symbol differ in at least one bit of first $\log_2 p_r$ bits, i.e., $\mathbf{H}_{rs}^{(n)} \neq \hat{\mathbf{H}}_{rs}^{(n)}$. In this case the resulting received signal at relay is

$$\begin{aligned} \hat{y}_r^{(n)} &= (\mathbf{u}_{rs}^{(n)})^H \mathbf{H}_{rs}^{(n)} \hat{\mathbf{v}}_{rs}^{(n)} x_s^{(n)} + (\mathbf{u}_{rs}^{(n)})^H (\mathbf{w}_r s_r^{(n-1)} + \mathbf{n}_r^{(n)}), \\ &= \lambda_{rs}^{(n)} (\mathbf{v}_{rs}^{(n)})^H \hat{\mathbf{v}}_{rs}^{(n)} x_s^{(n)} + \hat{w}_r s_r^{(n-1)} + \hat{n}_r^{(n)}, \\ &= \lambda_{rs}^{(n)} \gamma x_s^{(n)} + \hat{w}_r s_r^{(n-1)} + \hat{n}_r^{(n)}, \end{aligned} \quad (8)$$

where $\gamma = (\mathbf{v}_{rs}^{(n)})^H \hat{\mathbf{v}}_{rs}^{(n)}$, $\hat{w}_r \sim \mathcal{CN}(0, \sigma_{w_r}^2)$, and $\hat{n}_r^{(n)} \sim \mathcal{CN}(0, \sigma_r^2)$. Similar to case 1, the BER of this system is

$$\mathcal{B}_2 \leq \frac{1}{2^\eta} \sum_{x \in \mathbb{A}_s} \sum_{\tilde{x} \in \mathbb{A}_s \setminus \{x\}} \mathbb{E}_\gamma [\mathcal{R}(\hat{\beta}_{x,\tilde{x}}^2)] \frac{d_{x,\tilde{x}}}{\eta}, \quad (9)$$

where $\hat{\beta}_{x,\tilde{x}}^2 = (|\gamma|^2 |x - \tilde{x}|^2) / (\sigma_r^2 + \sigma_{w_r}^2 |s_r|^2)$. And the probability that at least one of the first $\log_2 p_r$ bits are decoded wrongly is

$$\mathcal{S}_2 \leq \frac{1}{2^\eta} \sum_{x \in \mathbb{A}_s} \sum_{\tilde{x} \in \mathbb{A}_s \setminus \{x\}} \mathbb{E}_\gamma [\mathcal{R}(\hat{\beta}_{x,\tilde{x}}^2)] g(x, \tilde{x}). \quad (10)$$

BER Expression From the Above Cases: From the above cases BER in different slots can be calculated as follows:

- Slot 1: In slot 1, there is no self interference at relay and always case 1 occurs, so BER is $P^{(1)} = \mathcal{B}_1|_{\mathbb{A}_r=0}$ and the PCER is $Q^{(1)} = \mathcal{S}_1|_{\mathbb{A}_r=0}$.
- Slot 2: In slot 2, case 2 occurs with $Q^{(1)}$ probability and case 1 occurs with $1 - Q^{(1)}$. So BER in slot 2 is $P^{(2)} = \mathcal{B}_1(1 - Q^{(1)}) + \mathcal{B}_2 Q^{(1)}$ and PCER is $Q^{(2)} = \mathcal{S}_1(1 - Q^{(1)}) + \mathcal{S}_2 Q^{(1)}$.

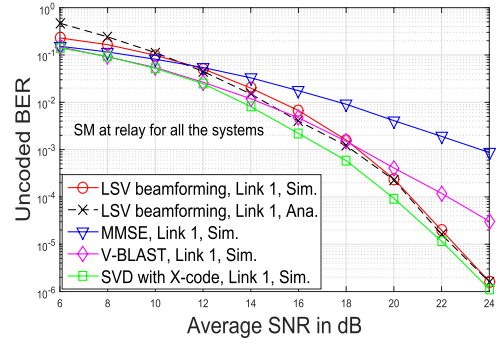

Fig. 2. The BER comparison of the FD-MIMO relaying system with SM at relay ($m_s = 2$, $n_d = 2$, $m_r = 4$, $n_r = 3$) and source beamforming with V-BLAST, MMSE, SVD with X-code precoders at source, at 4 bpcu.

- Slot n : Similarly in slot n , CER and PCER are

$$\begin{aligned} P^{(n)} &= \mathcal{B}_1(1 - Q^{(n-1)}) + \mathcal{B}_2 Q^{(n-1)}, \\ Q^{(n)} &= \mathcal{S}_1(1 - Q^{(n-1)}) + \mathcal{S}_2 Q^{(n-1)}. \end{aligned}$$

Therefore the average BER in link 1 is

$$\text{BER}_1 = \frac{1}{N} \sum_{n=1}^{n=N} P^{(n)}. \quad (11)$$

B. Link 2 BER Analysis

In the proposed protocol, link 2 (destination-relay) is using SM scheme for transmission. The BER expression for the SM system is presented in [5] as

$$\text{BER}_2 \leq \frac{1}{2^\eta} \sum_{\mathbf{x} \in \mathcal{SM}_{p_r, \mathbb{A}_r}} \sum_{\tilde{\mathbf{x}} \in \mathcal{SM}_{p_r, \mathbb{A}_r} \setminus \{\mathbf{x}\}} \text{PEP}(\mathbf{x} \rightarrow \tilde{\mathbf{x}}) \frac{d_{\mathbf{x}, \tilde{\mathbf{x}}}}{\eta}, \quad (12)$$

where $\text{PEP}(\mathbf{x} \rightarrow \tilde{\mathbf{x}}) = f(\alpha)^N \sum_{r=0}^{N-1} \binom{N-1+r}{r} (1 - f(\alpha))^r$, $f(\alpha) = \frac{1}{2} \left(1 - \sqrt{\frac{\alpha}{1+\alpha}} \right)$, $\alpha = \frac{1}{4\sigma^2} \sum_{k=1}^{n_t} \theta_k$, $\theta_k = |\mathbf{x}_k - \tilde{\mathbf{x}}_k|^2$ for all k and η is the spectral efficiency of the link in bpcu.

V. SIMULATION RESULTS

In this section, we present the analytical and simulation results of the proposed protocol in terms of BER. We compare the BERs of the proposed FD MIMO relay system using LSV based beamforming, with the system where the source uses either MMSE precoder [8], or V-BLAST [11] or SVD with X-code [10], and the relay uses V-BLAST. In all simulations, we assume the source and the destination have two antennas each ($m_s = n_d = 2$), and the relay has $p_r = 4$ antennas. We assume that each frame consists of $N = 130$ channel uses. For analytical results of link 1, we estimate \mathcal{B}_2 and \mathcal{S}_2 by Monte-Carlo simulations using 10^4 different realizations of γ .

In Fig. 2, we compare the BER in link 1 of the proposed LSV beamforming relaying system, with the system where source uses V-BLAST, MMSE (unweighted) precoder, or SVD with X-codes, for a fixed interference-to-noise ratio $\text{INR} = \sigma_{w_r}^2 / \sigma_r^2$ of 4 dB. All the schemes use SM at the relay ($m_r = 4$, $n_r = 3$), and the spectral efficiency is fixed to be 4 bpcu. To achieve the same spectral efficiency of 4 bpcu in all schemes, the source needs to transmit 16-QAM for source beamforming and two 4-QAM symbols for V-BLAST, MMSE, and SVD with X-code respectively.

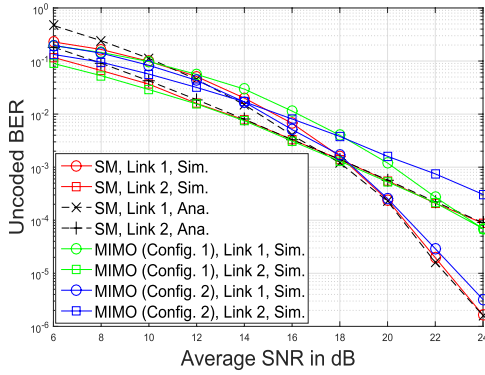

Fig. 3. The BER comparison of the FD-MIMO relaying system with SM at relay with MIMO Config. 1 and MIMO Config. 2 systems in terms of SNR.

From Fig. 2, we observe that, the derived analytical results are very close to the simulation and using beamforming at the source significantly improves the BER in link 1 compared to V-BLAST and MMSE, and this performance improvement increases at high SNR. This is due to the fact that the source beamforms to $p_r - 1$ antennas at the relay, which provides full transmit and receive diversity. At high SNR, the performance of LSV beamforming approaches that of X-code. However, the X-code has higher decoding complexity (ML detection) than LSV beamforming (linear decoder).

Fig. 3 compares the BER performance of *i*) the FD-MIMO relaying system, where the relay uses SM with $m_r = 4$, $n_r = 3$ and $\mathbb{A}_r = 4$ -QAM, *ii*) the FD-MIMO relaying system, where the relay uses V-BLAST with $m_r = 2$, $n_r = 2$ and $\mathbb{A}_r = 4$ -QAM (MIMO Config. 1), and *iii*) the FD-MIMO relaying system, where the relay uses V-BLAST with $m_r = 1$, $n_r = 3$ and $\mathbb{A}_r = 16$ -QAM at relay (MIMO Config. 2) for a fixed INR of 4dB with source beamforming. Note that, in all the systems, the total number of RF chains at relay is 4 and the spectral efficiency is 4 bpcu.

In Fig. 3, we show the individual BER performances of link 1 and link 2. From Fig. 3, we see that the BER of the proposed system is better than that of MIMO Config. 1 in link 1 (3 to 4 dB gain at 10^{-4} BER); but their BERs eventually become the same in link 2. This is because, in link 1, the relay using SM has one extra receive antenna, when compared to MIMO Config. 1 (only two antennas for reception). We also observe that the BER of the proposed system in link 2 is better than MIMO Config. 2 (3 to 4 dB gain at 10^{-3} BER), since MIMO Config. 2 uses a higher order QAM (16-QAM) than the proposed system using 4-QAM. In link 1, the performance of SM and MIMO Config. 2 are almost the same (small gap) as both are using 3 antennas for reception. This small gap is due to the interference signal effect at the relay. Hence, our proposed system using SM at the relay has better overall BER (approximately equal to sum of BER's in both links) than MIMO Configs. 1 and 2.

Fig. 4 compares the BER of the above three systems in link 1 in terms of INR at the relay as the INR effects only link 1. We assume that link 1 is operating at a SNR of 20 dB and the spectral efficiency of 4 bpcu. We observe that, in medium to low INRs (corresponding to the less interference cases), the proposed system outperforms MIMO Configs. 1 and 2. At higher interference cases, all the three

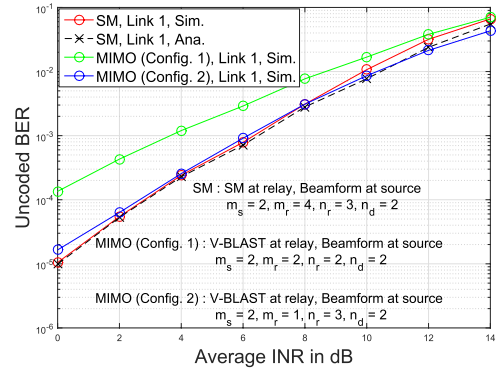

Fig. 4. The BER comparison of the FD-MIMO relaying system with SM at relay with MIMO Config. 1 and MIMO Config. 2 systems in terms of INR.

systems do not exhibit good performance because of SINR degradation at the relay.

VI. CONCLUSION

We studied the MIMO source-relay-destination network, where the relay is full duplex and uses spatial modulation for transmission. In particular, we proposed a transmission protocol for the MIMO network that effectively uses silent antennas at the relay for reception of the signals beamformed from the source, while the remaining antennas in the relay forward the previously decoded information using SM to the destination. We analysed the performance of the proposed system in both links in terms of BER. We then compared the error performance of the FD-MIMO relaying system, where the relay uses SM and V-BLAST, respectively for the same number of RF chains at the relay, and found the former performs better than the latter. This performance advantage is due to the availability of more antennas at the relay dedicated to reception and due to the use of lower order QAM in SM.

REFERENCES

- [1] J. I. Choi, M. Jain, K. Srinivasan, P. Levis, and S. Katti, "Achieving single channel, full duplex wireless communication," in *Proc. ACM MOBICOM*, New York, NY, USA, Sep. 2010, pp. 1–12.
- [2] M. Duarte *et al.*, "Design and characterization of a full-duplex multi-antenna system for WiFi networks," *IEEE Trans. Veh. Technol.*, vol. 63, no. 3, pp. 1160–1177, Mar. 2014.
- [3] R. Pabst *et al.*, "Relay-based deployment concepts for wireless and mobile broadband radio," *IEEE Wireless Commun. Mag.*, vol. 42, no. 9, pp. 80–89, Sep. 2004.
- [4] I. Krikidis, H. A. Suraweera, P. J. Smith, and C. Yuen, "Full-duplex relay selection for amplify-and-forward cooperative networks," *IEEE Trans. Wireless Commun.*, vol. 11, no. 12, pp. 4381–4393, Dec. 2012.
- [5] T. L. Narasimhan, P. Raviteja, and A. Chockalingam, "Generalized spatial modulation in large-scale multiuser MIMO systems," *IEEE Trans. Wireless Commun.*, vol. 14, no. 7, pp. 3764–3779, Jul. 2015.
- [6] B. Jiao, M. Wen, M. Ma, and H. V. Poor, "Spatial modulated full duplex," *IEEE Wireless Commun. Lett.*, vol. 3, no. 6, pp. 641–644, Dec. 2014.
- [7] P. A. Dighe, R. K. Mallik, and S. S. Jamuar, "Analysis of transmit-receive diversity in Rayleigh fading," *IEEE Trans. Commun.*, vol. 51, no. 4, pp. 694–703, Apr. 2003.
- [8] C.-C. J. Kuo, S.-H. Tsai, L. Tadjpour, Y.-H. Chang, *Precoding Techniques for Digital Communication Systems*. New York, NY, USA: Springer, 2008.
- [9] E. Soujeri and G. Kaddoum, "The impact of antenna switching time on spatial modulation," *IEEE Wireless Commun. Lett.*, vol. 5, no. 3, pp. 256–259, Jun. 2016.
- [10] S. K. Mohammed, E. Viterbo, Y. Hong, and A. Chockalingam, "MIMO precoding with X- and Y-codes," *IEEE Trans. Inf. Theory*, vol. 57, no. 6, pp. 3542–3566, Jun. 2011.
- [11] A. Goldsmith, *Wireless Communications*. Cambridge, U.K.: Cambridge Univ. Press, 2005.